

## Telephone User Guide

seethelight uses fibre to bring you high-speed internet and telephone services and therefore uses some equipment you may not be familiar with.

This guide demonstrates a typical equipment layout to get the best out of your telephone, and enable some of your telephone features, for example Voicemail or Call Barring.

---

## Your fibre equipment

Installed within your property is an Optical Network Terminal (ONT) - this is where the fibre enters your home.

The ONT can connect to your router to provide you with broadband, and your telephone for voice services.

The colour, model and location of your ONT may vary, however all you need to know are a few simple things...

## Ports you will find on your ONT

Below we show two basic ONT types but layout and colour of ports will vary depending on your actual model

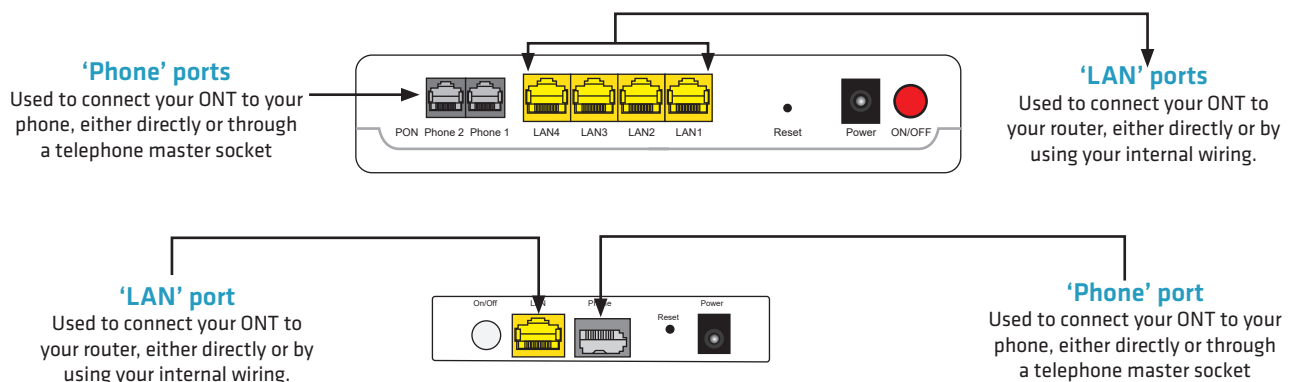



---

## Battery Backup Unit (BBU)

If you have a BBU installed, this will keep your ONT powered for up to 1 hour in the event of a power outage. This will allow you to continue to make and receive calls, including to the emergency services.

Always check your BBU is plugged in correctly and the lights are on. If the AC or OUTPUT lights are not glowing, call your internet service provider.

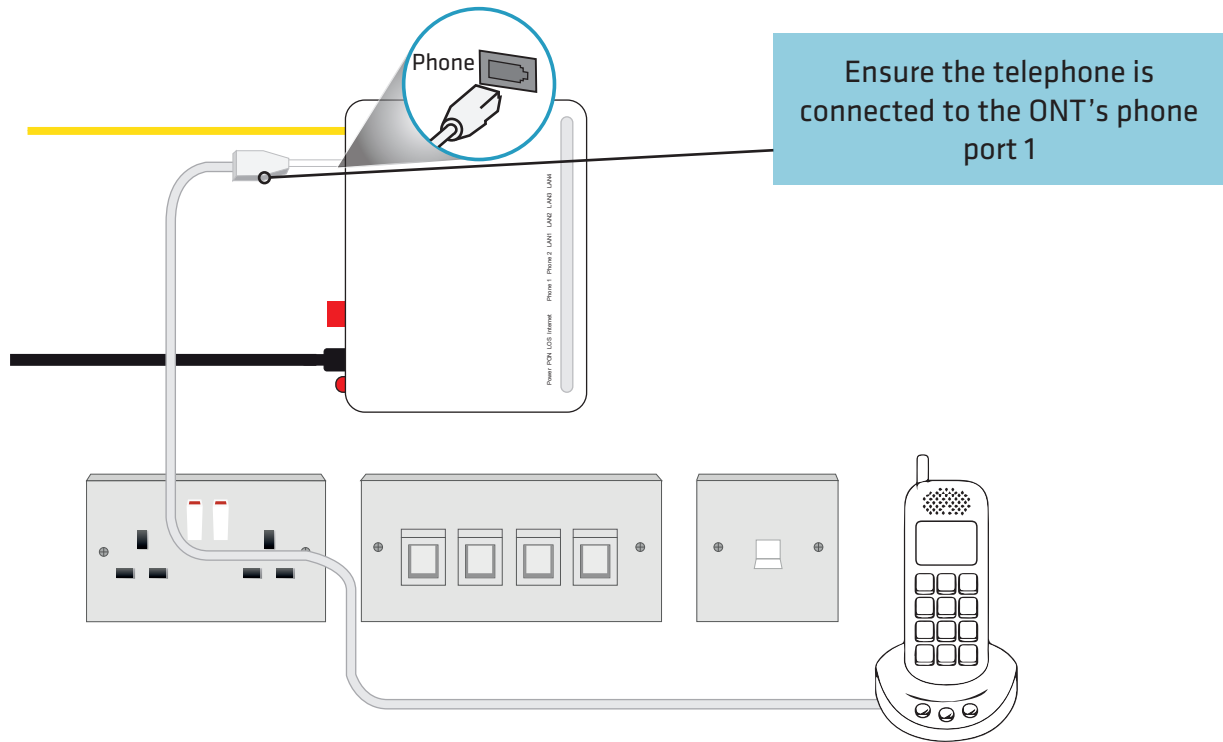
## Connection directly from your ONT to your telephone



---

## Connection from your ONT to your phone using your internal wiring

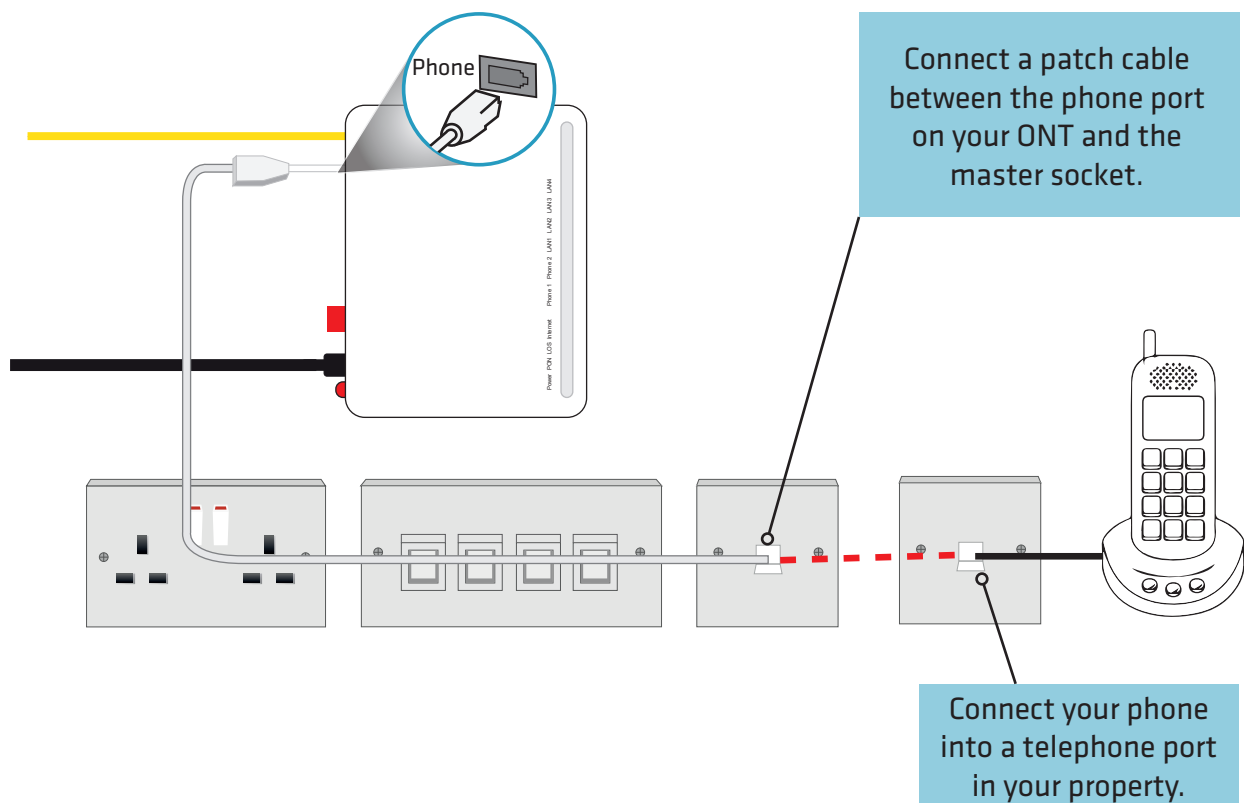

## Activating Call Features on your Handset

### Call Minder

This allows you to access your voicemail messages from any telephone.

#### How does it work?

To access voicemail from an external telephone, dial your home number, press # during the voicemail message and enter the user passcode. Before this service can be used, a passcode must be set up from your home handset. To enable the passcode, access the 1571 voicemail main menu, select option 3 and then option 3 again to enter the required password.

### Caller ID

This shows you the number that is calling you Note: This feature is handset dependent.

#### How does it work?

If you have a telephone that is compatible with this feature, it will display the number that is calling you (unless it's withheld).

Facility	Turn On	Turn Off	Check
Voicemail – Divert calls to voicemail when you are on the phone	Dial *67*1571#	#67#	*#67#
Voicemail – Divert calls to voicemail on no answer	Dial *61*1571#	#61#	*#61#
Call Waiting	*43#	#43#	*#43#
Anonymous Call Reject	*227#	#227#	*#227#
Divert the call when the line is busy	*67* [Phone number to divert to] #	Dial #67#	*#67#
Divert the call when there is no answer (the call will divert after 15 seconds).	*61* [Phone number you wish to divert to, then #	#61#	*#61#
Unconditional divert	*21* [Phone number to divert to] #	#21#	*#21#
Reminder Call - Turn your telephone into an alarm clock.	*55#	*#55#	
Bar all incoming calls to your telephone	*261#	#261#	*#261#
Group 1 - Bars all calls, excluding calls to emergency services	Dial *34* (insert group no.) #	#34* (insert group no.)* (insert password)	*#34* (insert group no.) #
Group 2 - Bars national, mobiles and international calls			
Group 3 - Bars international calls			
Group 4 - Bars all operator calls and services (e.g. Directory Enquiries)			
Group 5 - Bars calls to numbers with # or * in them (this can include some call features)			
Group 6 - Bars calls to premium rate numbers			
Group 7 - Bars calls to mobile numbers			

Note: Call barring uses the same password as the call minder feature. The password can be set by dialling 1571 and selecting option 3. Please note that there are certain numbers that you cannot bar, such as: - 999 Emergency services - 112 Emergency services - 0800 free numbers - 0500 free numbers - Calls to seethelight helpdesk